

KEEP FOR FUTURE REFERENCE



*P.O. Box 368 – 908 West Main
Laurel, MT USA 59044
phone 800-548-7341
phone 406-628-8231
fax 406-628-8354*

INSTRUCTIONS

International Version

STOCK NUMBER: 93011 & 93012

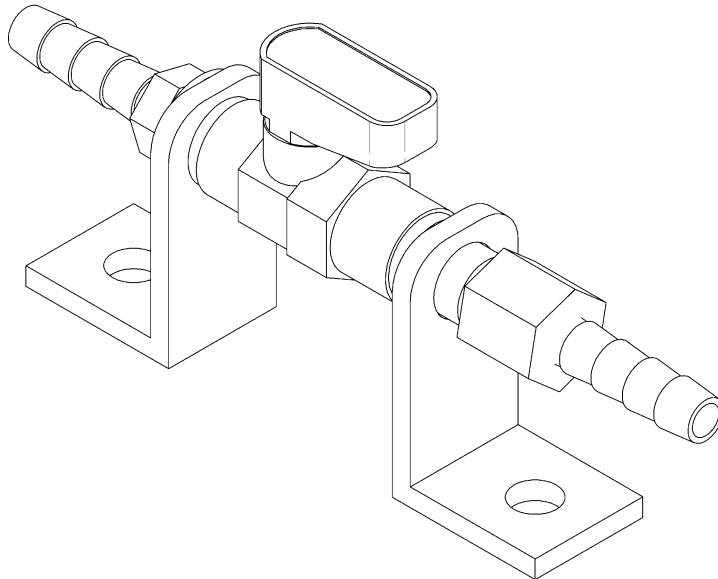

INDIVIDUAL VACUUM PAD SHUTOFFS



***READ ALL INSTRUCTIONS AND WARNINGS
BEFORE USING THIS PRODUCT***



DESIGNED FOR THE MATERIALS HANDLING PROFESSIONAL

SPECIFICATIONS

Stock Number: 93011 & 93012

Description: Manual valves on the pad frame enable a vacuum lifter to handle loads of various dimensions and weights by activating or deactivating vacuum flow at specific vacuum pads.

Weight: 0.4 lbs [0.2 kg] per pad shutoff
Note: Make sure to add the weight of all options to the Lifter Weight when you are selecting appropriate hoisting equipment (see ASSEMBLY in lifter's instruction manual).

Compatible Hoses: 7/32"-1/4" [6 mm] ID rubber or polyurethane vacuum hoses

WARNINGS



Powr-Grip is pleased to offer the most reliable materials handling products available. Despite the high degree of security provided by Individual Pad Shutoffs, certain precautions must be observed to protect the lifter operator and others.



Always install each pad shutoff as prescribed in the INSTALLATION section.

Never use a pad shutoff that is damaged, malfunctioning, or missing parts.

Never attempt to lift the maximum load capacity of the vacuum lifter while any vacuum pad is deactivated (see OPERATION).

Never allow any pad shutoff to be opened or closed while lifting.

Always remember that modifications to any pad shutoff may compromise its safety. Wood's Powr-Grip cannot be responsible for the safety of a pad shutoff that has been modified by the customer. For consultation, contact Wood's Powr-Grip (see LIMITED WARRANTY).

INSTALLATION

- 1) Verify that the vacuum lifter is equipped with compatible vacuum hose for installing Individual Pad Shutoffs (see SPECIFICATIONS).
- 2) Determine whether the lifter has been predrilled for pad shutoffs. If so, proceed to step 5. If not, select an appropriate location to mount a pad shutoff on the lifter: The object is to insert the pad shutoff into a vacuum line so that only one vacuum pad will be affected. Avoid locations that are difficult for the operator to access, that could interfere with lifter operations, or that could be weakened when drilled to mount the pad shutoff.
- 3) Using the brackets of the pad shutoff as a template, mark the location of the 2 mounting holes on the lifter's pad frame, and drill 0.201" (#7) diameter holes at the marked locations.
- 4) Thread the 2 mounting holes with a 1/4-20 tap.
- 5) Use the bolts and washers supplied to mount the pad shutoff securely on the pad frame.
- 6) Use the existing vacuum hose and vacuum fittings supplied as necessary to connect a single vacuum pad to the pad shutoff. Cut off used ends of vacuum hose when damaged, and make sure all vacuum hoses are attached securely to barbed fittings.
Note: If the vacuum pad is located at the end of a pad arm, vacuum fittings may not be needed to attach the vacuum hose to the pad shutoff.
- 7) Repeat steps 2-6 for each pad shutoff mounted on the lifter. Then perform a VACUUM TEST as directed in the lifter's instruction manual.

OPERATION

Operate the vacuum lifter as directed in the lifter's instruction manual, taking into account differences in load capacity and pad spread resulting from the use of Individual Pad Shutoffs, as follows:

Before applying the lifter to a load, activate or deactivate vacuum pads as needed for the load's specific weight and dimensions: To support the maximum load weight and larger load dimensions, all pads must be activated; for smaller weights and dimensions, some pads may be deactivated, ***provided that the lifter still has sufficient capacity to support the load.***

To activate a vacuum pad, open the pad shutoff (place valve lever *parallel* with vacuum line); to deactivate a pad, close the pad shutoff (place valve lever *perpendicular* to vacuum line). To calculate the lifting capacity when some pads are deactivated, consult the per-pad load capacity rating in the lifter's instruction manual, and multiply by the number of pads currently activated. ***Note that calculated lifting capacities may not exceed the maximum load capacity*** (see lifter's instruction manual).

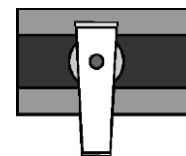

CLOSED
PAD SHUTOFF VALVE

 ***WARNING: Closing any pad shutoff reduces lifting capacity.***

Always activate vacuum pads in a symmetrical configuration, to keep the lifter balanced while lifting, and use as many pads as possible for each load, to maximize lifting capacity and to minimize load overhang. Since the allowable overhang is different for each kind of load material, consult the lifter's instruction manual to determine allowable overhang. Make sure that all activated pads will fit entirely on the load's contact surface and that they will be loaded evenly while lifting. After confirming that the configuration of activated pads is appropriate for a specific load, apply the lifter to the load as directed in the lifter's instruction manual.

 **WARNING: Never allow any pad shutoff to be opened or closed while lifting.**

Opening or closing a pad shutoff while the lifter is supporting a load could result in the release of the load and possible injury to the operator or others. The operator must take all appropriate measures to prevent any person or object from accidentally moving the lever of a pad shutoff during the lift.

MAINTENANCE

When performing inspections and tests of the vacuum lifter as directed in the MAINTENANCE section of the lifter's instruction manual, be sure to include each Individual Pad Shutoff whenever applicable.

REPLACEMENT PARTS

Stock No.	Description	Qty.
93012	Pad Shutoff Valve w/Brackets	as required

***SERVICE ONLY WITH IDENTICAL REPLACEMENT PARTS
SUPPLIED BY OR APPROVED BY WOOD'S POWR-GRIP CO., INC.***

LIMITED WARRANTY

Powr-Grip products are carefully constructed, thoroughly inspected at various stages of production, and individually tested. They are warranted to be free from defects in workmanship and materials for a period of one year from the date of purchase.

If a problem develops during the warranty period, follow the instructions hereafter to obtain warranty service. If inspection shows that the problem is due to defective workmanship or materials, Powr-Grip will repair the product without charge.

WARRANTY DOES NOT APPLY WHEN:

Modifications have been made to the product after leaving the factory.

Rubber portions have been cut or scratched during use.

Repairs are required due to abnormal wear and tear.

The product has been damaged, misused, or neglected.

If a problem is not covered under warranty, Powr-Grip will notify the customer of costs prior to repair. If the customer agrees to pay all repair costs and to receive the repaired product on a C.O.D. basis, Powr-Grip then will proceed with repairs.

TO OBTAIN REPAIRS OR WARRANTY SERVICE

For purchases in *North America*:

Contact the Technical Service Department at Wood's Powr-Grip Co. When factory service is required, ship the complete product--prepaid--along with your name, address and phone number to the street address hereafter.

For purchases in *all other localities*:

Contact your dealer or the Technical Service Department at Wood's Powr-Grip Co. for assistance.

Wood's Powr-Grip Co., Inc.
908 West Main St. / P.O. Box 368
Laurel, MT USA 59044

phone 800-548-7341

phone 406-628-8231

fax 406-628-83